

USB A FEEDTHROUGH CONNECTOR GROUNDED TO OUTER SHELL
 PRESSURE TESTED TO 1 BAR (UNMATED)
 CONTACT SALES OFFICE FOR TEST RESULTS

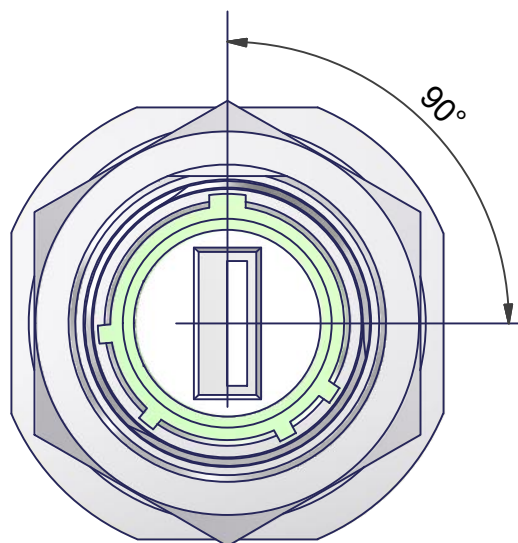

OPTION Y

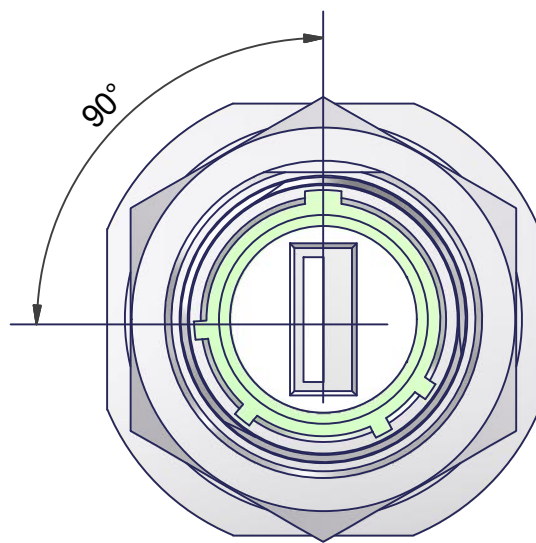

OPTION Z

NOTES
 GENERALLY TO THE REQUIREMENTS OF MIL-DTL-38999

MATERIALS
 USB A INSERT
 CONTACTS 30µ Au/Ni
 SHIELDING - NICKEL PLATED BRASS
 BODY - PA, UL94V-0
 PCB - FR4, UL94V-0

SEAL - SILICONE ELASTOMER
 INSULATOR - PPS GL40 UL94, COLOUR BLACK
 POTTING - QSIL 550 UL94V-0
PERFORMANCE
 CURRENT RATING 1 AMP MAX PER CONTACT
 VOLTAGE RATING 30V AC
 TEMPERATURE -25°C TO +85°C
 BULKHEAD SEAL PRESSURE-TIGHT TO 1 BAR

EXAMPLE PART NUMBER: PC4F0027-15NX-1-C	
PC4F0027 =	POLAMCO SERIES
15 =	SHELL SIZE
N =	ALTERNATE KEYING (N, A, B, C, D, E)
X =	INSERT ROTATION (X, Y, Z)
1 =	MATERIAL : SEE MATERIAL AND PLATING OPTIONS SHEET
C =	PLATING : SEE MATERIAL AND PLATING OPTIONS SHEET

PART NUMBER FOR UNGROUNDED OPTION PC4F0027-15NX-1-C-U

DRAWN	R.S.	DATE 22/03/2011	3RD ANGLE PROJECTION NOT TO SCALE	POLAMCO WESTON LOCK LOWER BRISTOL ROAD BATH BA2 1EP	PAGE 1 OF 1	UNLESS OTHERWISE SPECIFIED ALL DIMENSIONS IN MILLIMETRES
SALES APPR	M.F.	DATE 22/03/2011				
DESIGN APPR			THIS DRAWING IS COPYRIGHT AND THE PROPERTY OF POLAMCO LTD IT MUST NOT BE COPIED, USED FOR MANUFACTURE OR OTHERWISE DISCLOSED WITHOUT PRIOR WRITTEN CONSENT OF THE COMPANY.	ASSY USED ON: MIL-DTL-38999/24	MATERIAL SEE ABOVE	NCAGE CODE U5792
QUAL APPR						
ISSUE C	DCR					
WEIGHT	GENERAL TOL LINEAR +/-0.1MM ANGULAR +/- 1°					
			TITLE: USB A JAM NUT BULKHEAD FEEDTHROUGH ASSEMBLY			
			PART NUMBER: PC4F0027-15**-*-*		DRAWING NO: C4138	